

*Technical Description*

*For*

# **Multiple Lane Modular Vehicle Evaluation Station**

## **Model 354**

*Including*

**Laser Scanners, Doppler Radar, Weigh-In-Motion  
Sensors, Dual Tire Detector, Image Capture Camera  
and Processor**

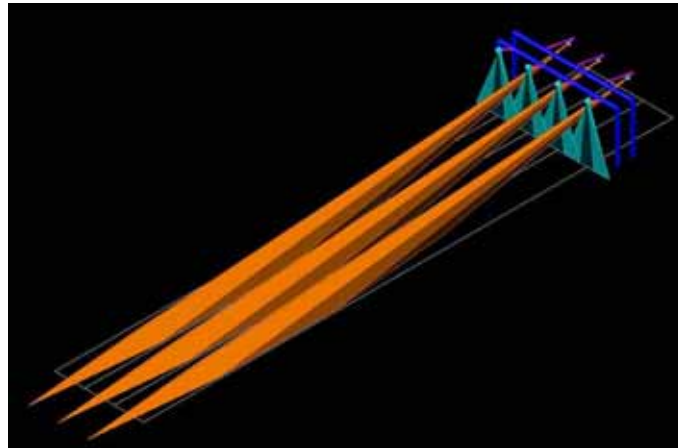

***TRANSPORT DATA SYSTEMS***



# Table of Contents

---

1.0	INTRODUCTION/SUMMARY .....	1
2.0	CUSTOMER REQUIREMENTS.....	1
2.1	Vehicle Alarm Selection .....	1
2.2	Image Capture.....	2
2.3	Accuracy.....	2
2.4	Vehicle Separation Performance.....	2
2.5	Interfaces.....	2
3.0	SYSTEM DESIGN.....	2
3.1	Operational Philosophy .....	5
3.2	Image Capture System.....	6
3.2.1.	Image Capture Software.....	7
3.2.2.	Image Capture Triggering.....	7
3.2.3.	Optical Character Recognition Software .....	7
3.3	System Software .....	7
4.0	DETAILED DESCRIPTION – EQUIPMENT.....	9
4.1	Laser Profiler.....	9
4.2	Eaton Vorad Doppler Radar .....	10
4.3	Axle/Weight Detection System .....	11
4.3.1.	Quartz Sensor .....	11
4.3.2.	Charge Amplifier.....	11
4.3.3.	Remote weigh processor Interface.....	12
4.4	Dual Tire Detector .....	13
4.4.1.	Fiber Treadle .....	13
4.4.2.	SPZ-Series Fiber Optic Traffic Sensors .....	13
4.4.3.	SL MD-220 Optical Transmittance Analyzer .....	13
4.4.4.	Fiber Treadle Quick Replacement Frame and Carrier .....	14
4.5	Camera.....	15
4.6	Image Capture Board.....	15
4.7	Enclosure .....	15
4.8	Illumination .....	15
4.8.1.	IR Illumination.....	15
4.9	Camera Mount.....	15
4.10	System Processor .....	15
5.0	INSTALLATION.....	17
5.1	Laser Scanner Installation.....	17
5.1.1.	Scanner Installation .....	17
5.1.2.	Scanner Power Supply Installation.....	17
5.1.3.	Scanner Cabling Installation.....	17
5.2	Radar Installation .....	18
5.2.1.	Radar Antenna Installation .....	18
5.2.2.	Radar Power Supply Installation .....	18
5.2.3.	Radar Cabling Installation .....	18



	Model 354 Vehicle Evaluation System	1261C Rosecrans Street San Diego, CA 92106 (619) 226-2534
---	-------------------------------------	---

## 1.0 INTRODUCTION/SUMMARY

The purpose of this document is to define the modular design of the TDS Multilane Vehicle Evaluation System. The basic system consists of Doppler radar, overhead laser scanners and weigh-in-motion sensors. The basic system can be augmented with dual tire detectors and front view image capture cameras to provide additional alarm selection capabilities as well as the capability of recording images of the vehicle for identification.

This system provides the capability of generating vehicle alarms based on a complex structure based on vehicle length, height profile, width profile, axle location, dual tires and weight per axle/tire.

This design is based upon TDS's extensive experience in the field of automatic vehicle classification, license plate capture and violation enforcement. TDS has over 400 lanes of high accuracy vehicle classifiers and image capture systems in operation today.

The TDS AVC design includes the use of a highly accurate Doppler radar system to provide vehicle velocity during the profiling and weighing processes. The addition of the quartz strips to the design in place of the treadle in the TDS RVES design provides a perfect match for weight detection. The accurate velocity that is required when using quartz sensors for weight calculations is inherent in the TDS system design.

The integration of image capture with weigh-in-motion and vehicle classification enables the user to improve weight enforcement and related infrastructure planning. The inclusion of this system into a weight enforcement strategy will lead to improved commercial vehicle safety, ensuring equitable competition in the commercial carrier industry and protecting public and private road assets from excessive and accelerated damage caused by overloaded commercial vehicles.

This technology has a number of applications in commercial vehicle weight enforcement, infrastructure development and road asset maintenance planning. It can be used to augment permanent weigh station operations by providing images and classifications for mainline WIM pre-screening systems, monitoring vehicle compliance to WIM sorter traffic signals and traffic signs, and for monitoring weigh stations evasion routes. It may also be deployed in conjunction with mobile and remote weight enforcement as a pre-screening system, or as an automated stand alone monitoring system on remote routes. The data from this system can provide agencies with a visual record from which to engage in discussions with particular carriers detected as chronic violators, or to assign preferred carrier status. The system may also be deployed in support of transportation planning activities to assist traffic engineers to evaluate future capital developments or help road asset managers plan preservation programs across specified segments of the road infrastructure. Other applications include urban weight enforcement and concentrated haul road weight enforcement. Finally the system can be employed on toll roads to provide a more equitable method of assessing costs for patron use of the road.

## 2.0 CUSTOMER REQUIREMENTS

### 2.1 Vehicle Alarm Selection

	Model 354 Vehicle Evaluation System	1261C Rosecrans Street San Diego, CA 92106 (619) 226-2534
---	-------------------------------------	---

The processor implements a complex table lookup selection system to allow generation of alarms based upon various parameters associated with the vehicle. This table can be easily modified to meet unique customer requirements. Selection criteria include length, width profile, height profile, and speed as well as individual axle/wheel weights. Depending on the sensor set that is implemented, the system can be easily programmed to issue an alarm if any combination of the selected vehicle characteristics are exceeded.

## **2.2 Image Capture**

The system will capture a front image of the vehicle for use in determining the ownership of the vehicle. A camera is dedicated to each lane.

## **2.3 Accuracy**

The RVES shall determine vehicle classes to an accuracy of at least 99%. The weight measurements shall have an accuracy greater than 95%.

## **2.4 Vehicle Separation Performance**

The system will differentiate between vehicles separated by a minimum of 3 meters at speeds of less than 50 miles per hour.

## **2.5 Interfaces**

The processor includes an Ethernet port for sending vehicle information including images to a central server.

## **3.0 SYSTEM DESIGN**

The dual lane system consists of 3 laser scanners, 2 Doppler radar, 2 dual tire detectors and 4 quartz sensors. Each quartz sensor will be 1 meter in length. The system can be delivered without the dual tire detector if the customer does not require it.

The block diagram for the two lane vehicle evaluation system is shown in Figure 3.0-1 below. This system is readily expandable to 3 or more lanes.

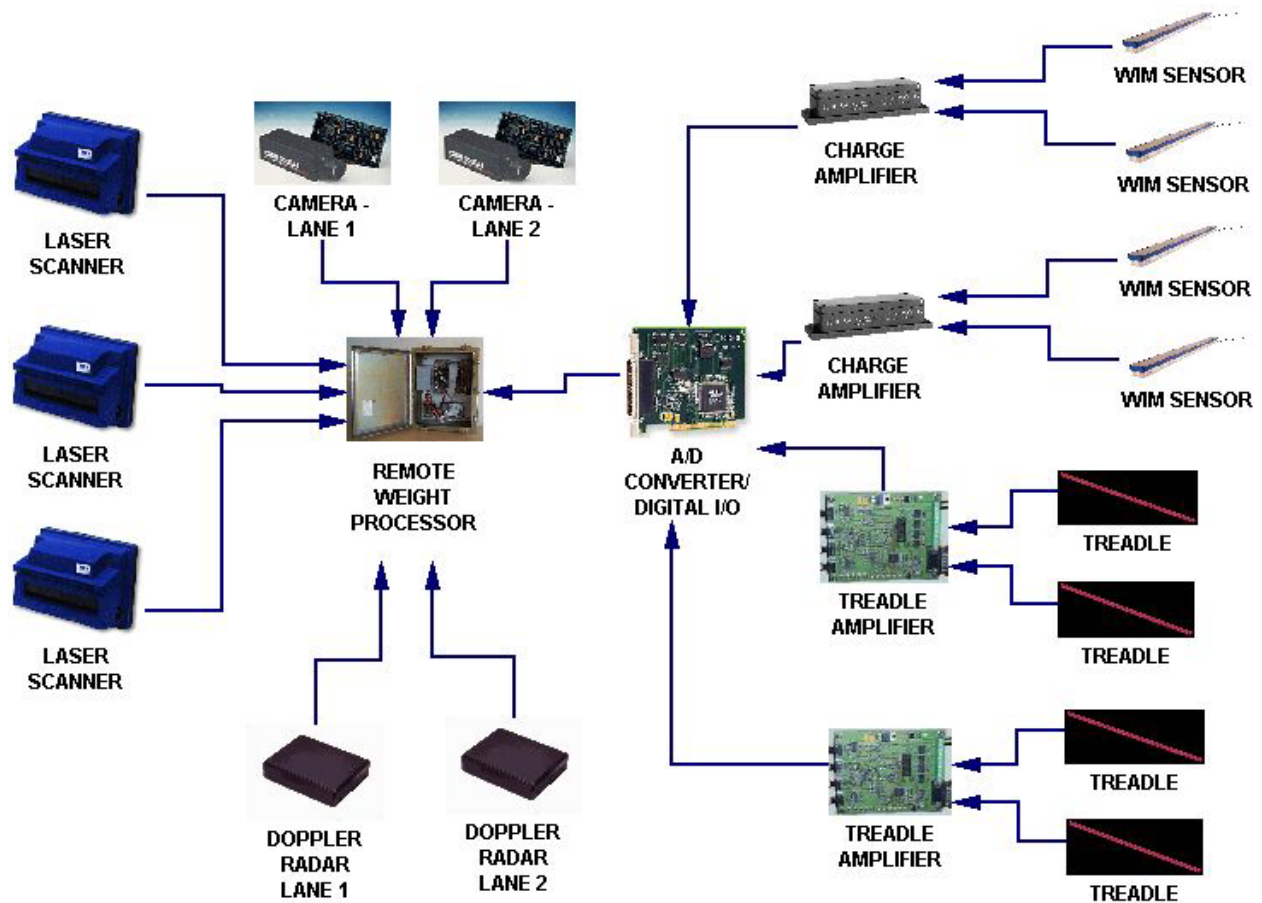

**Figure 3.0-1; Two Lane Vehicle Evaluation System Block Diagram**

The lane layout for the two lane vehicle evaluation system is shown in Figure 3.0-2 below. This system is readily expandable to 3 or more lanes.

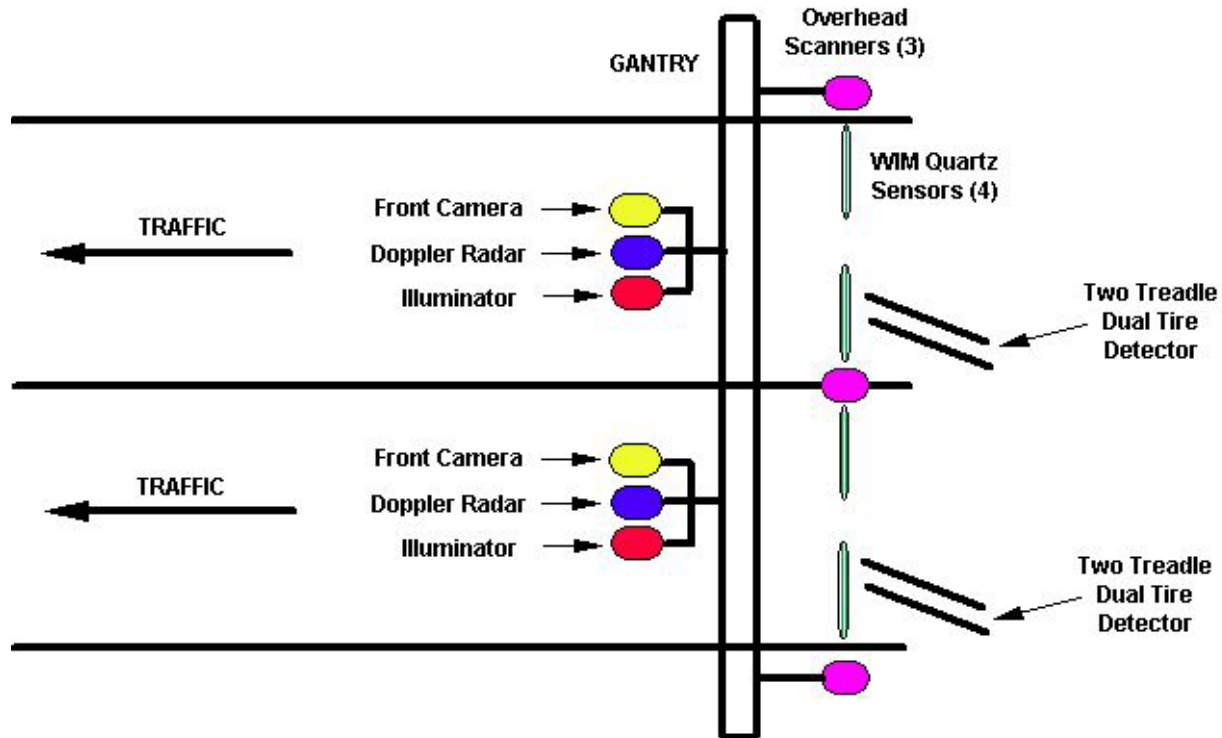

**Figure 3.0-2; Two Lane Vehicle Evaluation System Sensor Layout**

The system will generate alarms according to a set of rules. Table 3.0-1 shows a SAMPLE set of rules. The rule generation is extremely flexible and can be readily matched to particular customer requirements.

**Table 3.0-1; RVES Produced Alarms - Sample**

Vehicle Type	Alarm Number	Alarm Criteria	Vehicle Detection Criteria
2 Axle Truck	1	Rear Axle Weight > 5000 lbs.	Two axles, > 20ft without a van/bus profile (height > 6 feet) - Dual Tires
3 Axle Truck	2	Rear Wheel Weight > 20,000 lbs.	Three axles, Length, Axle Location, Height Profile. Dual Tires
4 or More Axle Trucks	3	Axle Weight > 20,000 lbs. OR Individual Tire Weight > 5,000 lbs. OR width > 9 feet OR height > 14.6 feet	Axle Count

The TDS system processor:

- Meets all of the individual vehicle discrimination and alarm generation based on axles, dual tires, vehicle weight and length and the height and width profiles of the vehicle.

	Model 354 Vehicle Evaluation System	1261C Rosecrans Street San Diego, CA 92106 (619) 226-2534
---	-------------------------------------	---

- Allows easy modification of alarm categories to readily accommodate future requirements.
- Provides accurate vehicle velocity (max and/or average) – accuracy = 1% +/- 0.2 mph.
- Maintains the position of the vehicle at all times while in the collection zone. This includes stop and go operation as well as reverse motion.
- Is composed of off-the-shelf technology from major suppliers.
- Can include a database and a web server for remote access and monitoring of alarms.

### 3.1 Operational Philosophy

The automatic vehicle classification system described herein is a pattern recognition system that relies on special pattern recognition algorithms to categorize vehicles into a number of distinct types. It uses the length of the vehicle, the number, weight and spacing of axles/tires, and height and width matrix depiction of the vehicle to form a complex pattern. This pattern is then fed to discrimination software that correlates with one of a predetermined set of vehicle and alarm types. A picture of an actual height profile of a five axle truck is shown in **Figure 3.1-1; Vehicle Profile**.

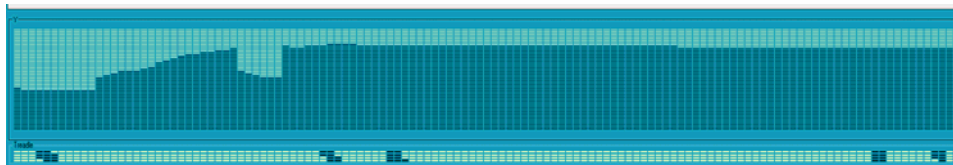

**Figure 3.1-1; Vehicle Profile**

Vehicle detection and profiling are accomplished by processing the sensor data from the radar, laser scanners, dual tire detectors and weigh-in-motion sensors. The processor receives frequent sensor messages from the radar and laser scanners. Each radar message reports the distance and velocity of up to seven targets that the radar is currently sensing in its beam. Each laser scanner message provides a report of the beam status of each of the individual beams. The axle sensor inputs are sampled each time a laser scanner message is received. The vehicle detection process begins when the laser scanner reports sufficient penetration concurrent with a radar report of an object moving in the vicinity of the lane in the path of the laser scanner beams. A filter is implemented to eliminate false classifications from being reported due to penetration of the laser scanner by objects other than vehicles.

The lasers are located at each side of the lane and between each lane at a height of approximately 25 feet. From this location, each laser can provide excellent height information about the vehicle and excellent width data relative to the near side of the vehicle(s). When the data from the two scanners is combined, it provides a very accurate width profile with no shadowing. It also provides an excellent two dimensional height profile of the top of the vehicle.

While the laser scanners are sufficiently penetrated, the processor creates a profile of the vehicle using the Doppler radar velocity information to determine which position in the vehicle profile to store each laser scanner and axle detection samples. This process continues until the laser scanners no longer detect a presence in the path of the laser scanner beams. The vehicle profile is then sent to the correlation process where the classification will be determined.

The correlation process begins with a series of tests to determine the characteristics of the vehicle. These characteristics are the length of the primary vehicle, the presence/location of a

	Model 354 Vehicle Evaluation System	1261C Rosecrans Street San Diego, CA 92106 (619) 226-2534
---	-------------------------------------	---

hitch, the maximum height of the primary vehicle, the maximum width of the vehicle, the number of axles and their weights and locations, the existence of dual tires. The test results are then correlated with a table of characteristic values that is configured for the user classification schedule. This table of characteristics is stored in a configuration file that is separate from the RVES application software. This provides an easy method for updating the class schedule should the user require modifications. After the classification has been determined the classification message is transmitted to the remote weigh processor application. The classification message includes the maximum velocity of the vehicle measured during the period that it was within the laser scanner. The message also includes the vehicle height, width, weights and length as well as the total axle count.

A key element in this design is the use of the CW Doppler radar. When vehicles are traveling at higher speeds, the problem of resolving two vehicles in close proximity is particularly vexing. However one characteristic that these two vehicles have in common is that their velocities are obviously very nearly the same. Therefore the Doppler return from each of the vehicles is also nearly the same. The laser scanner acts to provide excellent vehicle separation. The current design allows for separating two vehicles that are within 8 foot of each other at a velocity of 100 miles per hour. At more reasonable speeds (60 mph), the vehicles may be within four feet of each other and at manual lane speeds, the vehicles may be within 2 feet of each other. The processor uses the velocity provided by the Doppler radar to determine the positioning of the various samples in the vehicle profile. Since in this particular case the velocities of the two adjacent vehicles and the corresponding Doppler radar outputs are nearly identical, errors in the sampling distance that are due to returns from the adjacent vehicle are negligible.

The output from the Doppler radar provides an excellent measure of the vehicle velocity. This data is used to calculate the weight of each wheel set as the wheel crosses the quartz sensor. This data will be inserted into the local database as part of the primary vehicle alarm message.

### 3.2 Image Capture System

The Transport Data Systems license plate capture system uses a 1040 by 1392 digital area scan camera capable of operating in the full visible spectrum or in the near IR band.

This camera will provide high resolution lane coverage over a capture area of approximately 10 feet wide by 6 feet high. The size of this coverage coupled with accurate triggering insures that a single image will include the vehicle license plate. The resolution of the camera coupled with the low noise performance provides an excellent image for optical character recognition. TDS has developed a companion OCR package for use with this camera.

One camera is included per lane.

TDS can also supply the capture system with the necessary filters and LED illumination to allow operation in the near IR band. This method of operation provides enhanced plate detection and optical character recognition. The use of IR illumination eliminates the bright lights associated with full spectrum operation. This is especially important when front plates are being captured as it removes the safety hazard associated with blinding the driver of the vehicle. The privacy issue is also addressed as the image does not produce a recognizable picture of the driver. However, during nighttime operation, the image also does not include the vehicle. Only the license plate itself is visible.

	Model 354 Vehicle Evaluation System	1261C Rosecrans Street San Diego, CA 92106 (619) 226-2534
---	-------------------------------------	---

The digital video image is transmitted via a fiber link to a digital capture board located in a PCI slot in the processor. A serial RS422 link from the digital capture board provides a means for initialization and control of the camera by the processor.

### 3.2.1. Image Capture Software

The image capture software application receives the trigger and triggers the camera to capture an image. The camera captures the image and then downloads the data to the Processor memory via the high-speed digital fiber interface. The image is then stored on the hard drive in an uncompressed raw format. The application then either uploads the image to the next level user or performs the OCR process locally. The remote weigh processor generates a transaction for upload to a central processor.

### 3.2.2. Image Capture Triggering

Each of the cameras is independently triggered. The LPR image capture software receives a trigger from the triggering application. The trigger is developed from the lane sensor information.

The trigger is generated when a vehicle enters the capture zone defined by the vehicle separator. This integrated mechanism provides an extremely accurate trigger for both cameras. The lane geometry is shown in **Figure 3.0-2**.

### 3.2.3. Optical Character Recognition Software

Transport Data Systems has developed and tested a plate locator and associated optical character recognition package specifically designed to extract ASCII representations from license plates that have been photographed using the Wintriss Engineering 1500 series camera. This OCR can be implemented in the Remote weigh processor. The OCR process works best with uncompressed images. This system will perform the OCR process on the uncompressed images and then compress the images for storage and transmission to the next higher level. The extraction of the license number at the Remote Vehicle Evaluation System will also enhance the ability of the local site to select and examine specific transactions and to provide this selection capability externally through the RVES web interface. Furthermore should the end user ever decide to outsource the violation processing, the vendor would not have to deal with the OCR process for the specific image capture process as implemented by the end user.

As each violation transaction is received, it will be processed and entered into the database. The associated images will be processed by the OCR software and then compressed. The compressed images will be stored in the database along with the license plate number and the quality data developed during the OCR process.

## 3.3 System Software

The system software can provide any/all of the following functions:

- Receipt of data from the radar
- Receipt of data from the laser scanners
- Receipt of data from the axle detection and weighing equipment
- Camera triggering and image capture for front and side view cameras.
- Image storage and transaction storage – Offending vehicles.
- Vehicle presence detection
- Vehicle position tracking through the collection zone

	Model 354 Vehicle Evaluation System	1261C Rosecrans Street San Diego, CA 92106 (619) 226-2534
---	-------------------------------------	---

- Determination of the vehicle classification based on sensor inputs.
- Vehicle speed
- Profiler entry and exit messages
- System diagnostics (remote or local)
- Error reporting to the central server.
- Output of data to the central server or to a remote vehicle.

The processor will be able to handle all types of vehicle motion including negative speeds. It will identify back-outs and terminate the transaction.

	Model 354 Vehicle Evaluation System	1261C Rosecrans Street San Diego, CA 92106 (619) 226-2534
---	-------------------------------------	---

## 4.0 DETAILED DESCRIPTION – EQUIPMENT

### 4.1 Laser Profiler

The laser profiler is a model LMS211 produced by Sick Optic-Electronic. It is a non-contact measuring system that scans its surroundings two dimensionally. The scanner does not require any reflectors or positional markers to function as a scanning system.



The LMS 211 operates by measuring the time of flight of laser light pulses. The time between emission and reception of a light pulse, after it has been reflected from a surface, is directly proportional to the distance between the light source and the object. The laser can scan a large area by using a pulsed laser beam deflected by a rotating internal mirror. The LMS can produce the contour of an object using a rapid sequence of distance measurements. The serial data itself is sent to the remote weigh processor in real time via the RS-422 link.

The unit operates at a scanning rate of 75 scans per second. The scan angle that is reported is programmable. For this application it will be set to 68 degrees. The beam width of the laser beam is approximately 1 degree. The reported angular scanning resolution is programmable. For this application it will be set to 4 degrees, resulting in 17 segments being reported per scan. The range resolution of this configuration is approximately 50 millimeters.

The unit includes internal heaters for environmental control. A built-in thermostatically controlled heater and a front screen heater enable the LMS to be used at temperatures to minus -30 degrees Centigrade. The heaters are activated at 10 degrees Centigrade to prevent any thawing from occurring within the unit.

The unit is delivered with an optional dust prevention shield. This shield prevents direct exposure of the front screen to precipitation or sources of dirt.

The scanner unit weighs approximately 9 kilograms. The unit is delivered with a separate mounting bracket that provides adjustment of the device in both of the relative axes.

The electronic part of the sensor is powered directly from a regulated 24 VDC 1 amp power supply. The scanner heater is also powered from 24 VDC at 6 amps. The heater supply does not require regulation. Both the electronics and the heaters can be powered from the same primary power supply if desired.

TDS provides a maintenance screen in the RVES software package that allows a technician to easily align the scanner and configure the height and lane width settings during installation.

	Model 354 Vehicle Evaluation System	1261C Rosecrans Street San Diego, CA 92106 (619) 226-2534
---	-------------------------------------	---

## 4.2 Eaton Vorad Doppler Radar

The Doppler Radar consists of the following components:

- Radar Antenna assembly
- Power Supply (110/220 VAC)
- Radar Mount
- Power and communication cables
- RS422 interface to RVES Processor



The Doppler CW radar is a Ku band (24.725 Ghz) radar produced by Eaton Safety Systems. It is designed to provide coarse position and very accurate velocity data on moving vehicles. Coarse position is provided by a 50 kilohertz frequency shift keying applied to the transmitted signal. Velocity data is provided by the Doppler offset of the received signal. The received signal is mixed with a coherent transmitter signal to produce in-phase and quadrature Doppler signals, which are then sampled and fed to a digital signal processor, implemented as a Fast Fourier Transform (FFT). The outputs of the FFT are correlated with the coarse range data to provide data on up to seven separate targets.

The radar was originally designed to be part of a vehicle mounted collision avoidance system that is now being sold in production quantities by Eaton. The radar is a weatherproof unit, packaged to withstand extremes in temperature and humidity. As sold by Eaton, the unit is mounted above the front bumper on a vehicle and provides target information about vehicles directly ahead of the instrumented vehicle.

The radar is a very low power device (< 5 milliwatts CW). It has complete FCC approval (FCC ID I3L3JC) for operation on the open road and is not an RF hazard to humans under any conditions.

The antenna unit is a planar array. The horizontal beam width is 12 degrees and the vertical beam width is 4 degrees.

The radar processor provides a variable length message containing range and range rate on up to seven targets to the processor. This message is transmitted to the processor every 65 milliseconds. The interface is a 19200 bps RS-422 interface. The resolution of the range is 1 foot and of the range rate is 0.1 foot per second. The accuracy of the range reading has limited value as the phase center tends to move about the vehicle as it passes through the radar beam. On the other hand the accuracy of the range rate is 1% +/- 0.2 miles per hour. The unit will handle velocities up to a maximum of 120 miles per hour and ranges up to 350 feet.

The unit is capable of operating in a temperature range of - 40 degrees to + 85 degrees Centigrade.

The radar requires a maximum of 10 watts of power from a regulated 7.5 VDC source. As shown in Figure 3.0-2, the Doppler radar are mounted approximately 15 to 18 feet “downstream” of the saser scanners, with the top of the antenna positioned 16 to 18 feet above

	Model 354 Vehicle Evaluation System	1261C Rosecrans Street San Diego, CA 92106 (619) 226-2534
---	-------------------------------------	---

the road surface. Each radar should be located exactly over the center of its associated lane. Each radar should have an unobstructed view of the lane to the road surface. Each radar power supply must be located within 6 feet of the associated radar unit.

### 4.3 Axle/Weight Detection System

The axle/weight detection system in each lane will consist of two quartz sensors connected to a charge amplifier. Depending upon the width of the lane, each sensor will be 1.0 meter, 1.5 meter or 1.75 meters in length. In the event the user does not require separate weights for each individual tire on the axle, a single quartz sensor can be constructed with a sufficient length to cover the entire width of the lane.

#### 4.3.1. Quartz Sensor

Kistler's LINEAS WIM Type 9195C is a force sensor with quartz elements. The sensor is a modular element that is installed into a slot that is saw-cut across an asphalt or concrete road. When a force is applied to the sensor surface, the quartz disks yield an electric charge proportional to the applied force through the piezoelectric effect. The electric charge is converted by a charge amplifier into a proportional voltage which can then be processed as required. Key characteristics include:

- Excellent long term stability.
- Measures very accurately at both walking and freeway speeds.
- Insensitive to temperature changes.
- Frost-resistant and protective against ingress of water.
- Quasistatic and dynamic calibration is possible.
- Wide measuring range.

The sensor is not dislodged from the road and can be reground by up to 10 mm in the event of road deformations.

The sensors are available in 0.75 and 1.0 meter lengths. Two or more sensors can be connected together to make a longer single sensor strip. Several sensors that are installed adjacent to one another can be connected electrically in parallel and operated with a single charge amplifier. The output signal then corresponds to the sum of the forces acting simultaneously on all sensors connected.

#### 4.3.2. Charge Amplifier

The industrial charge amplifier (Type 5038A2Y43) is a 2 channel amplifier. Each channel converts the charge output of the Lineas sensor to a proportional voltage. The adjusting potentiometers are designed as plug in units to avoid the need for recalibration when an amplifier is replaced. The unit requires an unregulated 15 to 20 volt DC supply. Its key features include:



- Robust aluminum diecast housing
- Vibration proof
- No adjustments required

	Model 354 Vehicle Evaluation System	1261C Rosecrans Street San Diego, CA 92106 (619) 226-2534
---	-------------------------------------	---

#### 4.3.3. Remote weigh processor Interface

The outputs of the sensor amplifier are brought to the remote weigh processor over special cables capable of extending the distance from the sensor amplifier to over 80 feet. The signals are fed into a digital processing card that contains a 12 bit analog to digital converter.

	Model 354 Vehicle Evaluation System	1261C Rosecrans Street San Diego, CA 92106 (619) 226-2534
---	-------------------------------------	---

#### 4.4 Dual Tire Detector

The dual tire detection will use two fiber optic treadles, each with a length of 1.7 meters. The two fiber optic treadles are placed at a nominal 35 centimeter (14 inch) separation at an angle of 30 degrees relative to the flow of traffic.

##### 4.4.1. Fiber Treadle

The fiber optic treadle is manufactured by Sensor Line. The fiber treadle installation will include the following items:

- SPZ-Series Fiber Optic Traffic Sensors
- SL MD-220 Optical Transmittance Analyzer

##### 4.4.2. SPZ-Series Fiber Optic Traffic Sensors

These sensors can be provided with lengths up to 4m. Sensitivity can be varied from few grams up to many tons by selecting the mode of installation. Their completely non-metallic structure ensures highest protection against any kind of electromagnetic interference. The SPZ-series sensors have a fiber optic structure fitted into a special conduit and are designed for permanent embedding into the road surface. The materials used enable a range of in-ground operating temperature from -40°C to +80°C (-40°F to 176°F). The feeder cables are spliced to the sensor fiber, so the feeder type and length must be specified in advance. They can be obtained with or without connectors.

##### 4.4.3. SL MD-220 Optical Transmittance Analyzer

The SL MD-220 Optical Transmittance Analyzer is a small dynamic (AC-coupled) dual channel interface device in a plastic module housing. It can also be used for simple static (DC) measurements. An internal Schmitt-Trigger with light-level-controlled threshold enables sensor-independent trigger sensitivity. The unit includes internal failure detection to indicate out-of-range conditions (e.g. torn fiber) by a particular output signal.



The unit provides optocoupler outputs for trigger and failure signals. The analog signal outputs are short-circuit-protected. The input power connections include reverse power protection. No adjustment necessary to the unit. The unit uses a powerful IRED transmitter (Laser Class 3A when fiber disconnected). This is suitable for feeder lengths up to 250m.

The SL MD-220 is an interface ideally suited for all common axle detection, axle counting and speed measuring purposes, but also a convenient means to simply feed light into an optical fiber or measure light emerging from a fiber. It is designed in a way that it can easily be configured to meet a maximum number of custom requirements as well as extended by supplementary circuits for additional functionality.

The SL MD-220 feeds a variable amount of light into the fiber thus providing automatic adaptation for much larger variations of the sensor and feeder transmittance.

#### 4.4.4. Fiber Treadle Quick Replacement Frame and Carrier

The fiber treadle is designed to be installed directly into the roadway using a special epoxy to encapsulate the fiber treadle. This provides excellent performance. However in the event of a failure of the treadle, the encapsulation and the enclosed fiber treadle must be physically removed from the roadway and replaced. This will typically remove the lane from service for a minimum of 24 hours while the epoxy cures.

In those applications where a quicker replacement is required, TDS offers a steel treadle frame and carrier combination. The frame is installed into the roadway and the carrier is then bolted into the frame. The fiber treadle is encapsulated with resin into the carrier by TDS. The user then installs the carrier into the frame. The fiber cable is routed through the junction box on the end of the frame. This is shown in **Figure 3.8.4-1; Fiber Treadle Carrier and Frame.** This allows for the replacement of a failed treadle in less than two hours using standard tools.

**Figure 3.8.4-1; Fiber Treadle Carrier and Frame.**

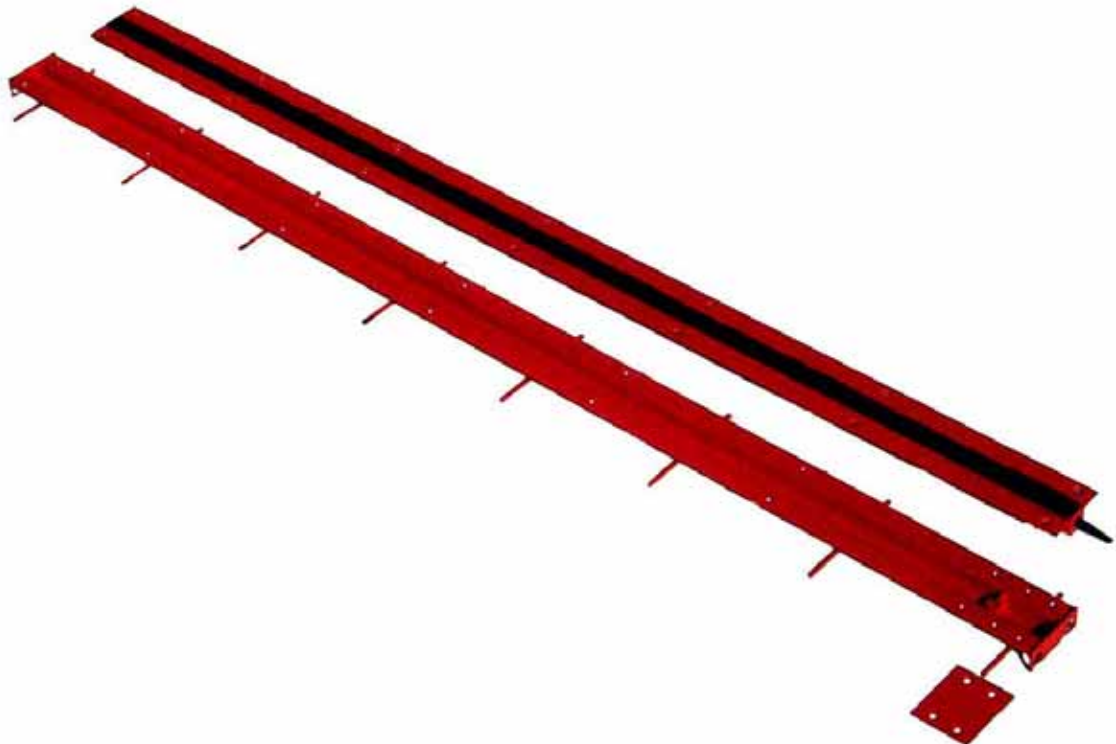

#### 4.5 Camera

The camera is a Wintriss Engineering Model 1500. It is a digital area scan camera with the following characteristics:

- Resolution: 1392 x 1040 pixels monochrome
- Pixel size: 7.4 mm x 7.4 mm
- Aspect ratio: 5:4
- 8 bit video front end.
- RS422 bi-directional 115kbit/sec serial link for camera initialization and control
- Electronic shutter: 1 millisecond to 10 seconds.
- 330 megabit/second serial digital video fiber output.
- Operation in visible and near IR spectrums.



#### 4.6 Image Capture Board

Each camera is interfaced into a PCI bus image capture card with the following characteristics:

- 256k 32 bit word receiver FIFO
- Sixty-four 32 bit word transmitter FIFO
- DMA access to host memory
- RS422 bi-directional 115kbit/sec serial link for camera initialization and control

Two cameras can be installed in every lane and two associated image capture boards can be installed in the processor assigned to that lane.

#### 4.7 Enclosure

A Pelco enclosure is provided for mounting the camera and power supply. It is a Pelco EH4718-1 Housing. It includes an environmental control unit. Where required, the Pelco SS4718 Sun Shroud is also provided.



#### 4.8 Illumination

The cameras which capture the image of the front of the vehicle must use Infrared (IR) illumination.

##### 4.8.1. IR Illumination

IR illumination will be provided by two 192 LED arrays per camera. Each LED array consumes approximately 24 watts. The illumination is continuous. This illuminator operates at 880 nanometers. It is mounted directly below the camera on the mount so that it points wherever the mount is pointing. The illuminator is barely visible to oncoming traffic and as such does not represent a safety risk to the vehicle operator.

#### 4.9 Camera Mount

TDS uses a variety of different PELCO mounts to meet different mount requirements.

#### 4.10 System Processor

TDS offers a choice of two different processors. One is for installation inside a controlled environment like the plaza and the other is for external installations.



For the inside installation, the processor is a Dell Series 600 server or equivalent. It uses a P4 processor. It includes 512 megabytes of RAM and a 20 Gb hard drive. It will contain an Ethernet port for LAN connection. The unit will run the Linux operating system.

For an external installation, the processor is a hardened PC designed to be installed in tunnels and open air booths. It uses a P4 processor. It includes 512 megabytes of RAM and a 20 Gb hard drive. It will contain an Ethernet port for LAN connection. The unit will run the Linux operating system. The unit is equipped with a heat exchanger to allow for completely sealed operation.



The unit will be equipped with a multichannel RS-422 serial channel board for interfacing to the sensors..

## 5.0 INSTALLATION

### 5.1 Laser Scanner Installation

The laser installation consists of:

- Mounting the laser mount on the overhead structure.
- Mounting the laser power supply near the scanner. The laser power supply will need to be put into an enclosure for external mounting.
- Installing a single cable between the power supply and the scanner.
- Installing a single cable between the scanner and the RVES processor.

The laser scanners must be installed overhead at a height of approximately 25 feet from the road surface.

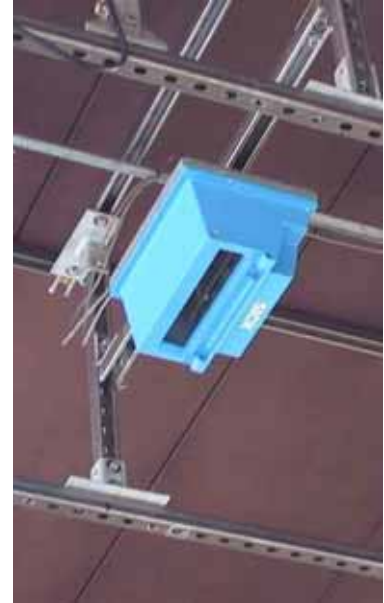

#### 5.1.1. Scanner Installation

The scanner is supplied with a mounting bracket for attachment to the structure. The mount is adjustable to allow for alignment of the scanner.

#### 5.1.2. Scanner Power Supply Installation

The scanner requires a special 24 volt DC power supply. TDS will supply this power supply in a separate rugged container for installation near the scanner installation. The power supply for the scanner must be mounted either on the gantry or at the base of the gantry

#### 5.1.3. Scanner Cabling Installation

The scanner is connected to the RVES processor via an RS-422 link. A single cable connects the scanner to the RVES processor and the scanner power supply. The cable will be supplied with the scanner connector installed and the RVES processor connections left un-terminated. This cable should be run inside of a conduit to the RVES processor location.

	Model 354 Vehicle Evaluation System	1261C Rosecrans Street San Diego, CA 92106 (619) 226-2534
---	-------------------------------------	---

## 5.2 Radar Installation

The radar installation consists of:

- Mounting the radar mount on the gantry.
- Mounting the radar power supply near the radar antenna. The radar power supply will need to be put into an enclosure for external mounting.
- Installing a single cable between the power supply and the antenna.
- Installing a single cable between the radar and the processor.

### 5.2.1. Radar Antenna Installation

TDS has designed and built a small pedestal mount for the Doppler radar. The mount is adjustable in both azimuth and elevation. The mount is adjustable in both azimuth and elevation to allow for beam alignment of the radar.

### 5.2.2. Radar Power Supply Installation

The radar requires a special 7.5 volt DC power supply. TDS will supply this power supply in a separate rugged container for installation near the radar installation. This unit must be installed within 3 meters of the radar.

### 5.2.3. Radar Cabling Installation

A single cable connects the radar antenna/processor to the RVES processor and the radar power supply. The cable will be supplied with the radar connector installed and the power supply/RVES processor connections left un-terminated.

## 5.3 Quartz Sensor Installation

Special sand/epoxy grout secures the sensor strips into the pavement slots. After curing, the hardened grout and the exposed top surfaces of the sensor modules are ground flush with the surrounding pavement using a belt sander. After grinding, the sensors may be immediately exposed to traffic. An overnight post cure is recommended before calibration and acceptance tests are performed.



Installation instructions for the installation of the sensors will be provided by TDS. The potting compound used to install the sensors will be supplied by TDS.

## 5.4 Quick Replacement Treadle Installation

The use of the treadle frame and carrier allow for quick replacement of the treadle in the event of a failure. In this installation, the treadle frame is permanently installed into the concrete. A conduit is connected to the junction box for routing of the fiber connection to the treadle

interface box installed near the remote weigh processor. The junction box with the cover on and the cover removed are shown in **Figure 5.3.2; Fiber Treadle Frame Junction Box**.

The treadle carrier is delivered by TDS with the treadle already potted in place. Once the frame has been installed, the treadle carrier is bolted into the frame. Then the fiber is pulled through the conduit and the cover plate is installed.

**Figure 4.4; Fiber Treadle Frame Junction Box**

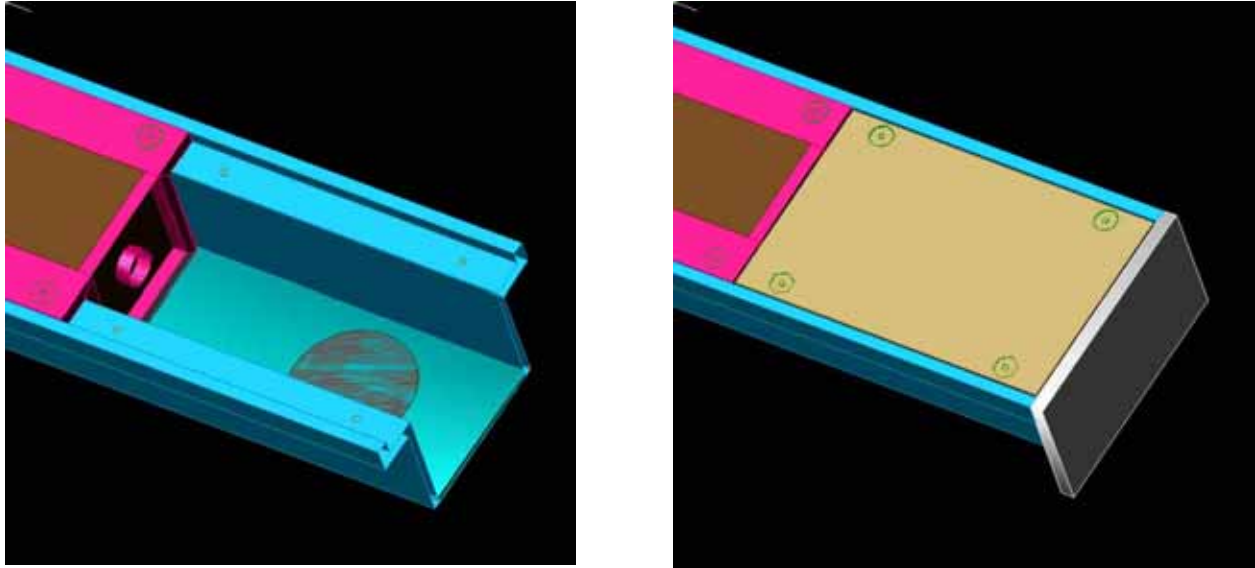

### 5.5 Camera Installation

The front camera is mounted at a height of 16 to 18 feet above the ground at a location directly centered over the lane. It is located approximately 18 feet downstream from the laser scanner. The illumination is co-located with the camera.



	Model 354 Vehicle Evaluation System	1261C Rosecrans Street San Diego, CA 92106 (619) 226-2534
---	-------------------------------------	---

## 5.6 System Processor Installation

The RVES processor can be located anywhere within 500 feet of the lane. All cabling from the lane to the RVES will be either RS-422 copper or fiber optics.