

Technical Description

For

Model 310 Automatic Vehicle Classification System

Including

10 Foot Light Curtain, Doppler Radar, Weigh-In-Motion Sensors and AVC Processor

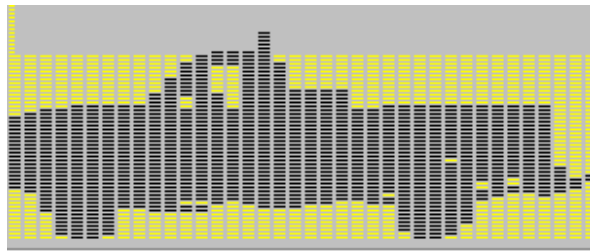

TRANSPORT DATA SYSTEMS



The information disclosed herein contains proprietary rights of Transport Data Systems, Inc. Neither this document nor the information disclosed herein shall be reproduced or transferred to other documents or used or disclosed to others for manufacturing or any other purposes except as specifically authorized in writing by Transport Data Systems, Inc.

Table of Contents

1.0	INTRODUCTION/SUMMARY	1
2.0	CUSTOMER REQUIREMENTS	1
2.1	Vehicle Classes.....	1
2.2	Accuracy.....	1
2.3	AVC Vehicle Separation Performance.....	1
2.4	Interfaces	1
3.0	SYSTEM DESIGN.....	1
3.1	AVC Operational Philosophy	4
4.0	DETAILED DESCRIPTION – EQUIPMENT	6
4.1	STI Light Curtain.....	6
4.1.1.	Curtain Array	6
4.1.2.	Curtain Processor.....	6
4.1.3.	Stanchion Enclosures.....	6
4.2	Eaton Vorad Doppler Radar.....	8
4.3	Axle Detector.....	9
4.3.1.	Quartz Sensor	9
4.3.2.	Charge Amplifier	9
4.3.3.	Lane Controller Interface.....	10
4.4	AVC Processor	10
5.0	INSTALLATION.....	11
5.1	Curtain Installation.....	11
5.1.1.	Transmit/Receive Tower Installations.....	11
5.1.2.	Curtain Processor Installation.....	11
5.1.3.	Curtain Cabling Installation.....	11
5.2	Radar Installation	12
5.2.1.	Radar Antenna Installation.....	12
5.2.2.	Radar Power Supply Installation.....	12
5.2.3.	Radar Cabling Installation.....	12
5.3	Quartz Sensor Installation	12
5.4	AVC Processor Installation.....	13

1.0 INTRODUCTION/SUMMARY

The purpose of this document is to define the design of the Model 310 AVC Classification Equipment. This system provides the capability of classifying vehicles into a complex class structure based on vehicle length, height profile and axle location/w eight.

2.0 CUSTOMER REQUIREMENTS

2.1 Vehicle Classes

The following is a generalized list of vehicle classes. The final product will be customized to meet the customer class table.

- i) Motorcycles (exceeding 50cc)
- ii) Motor cars with and without trailers within given weight ranges
- iii) Buses or coaches within given weight ranges
- iv) Light trucks – 2 axle with or without trailers within a given weight range
- v) Heavy trucks – 3 axles with or without trailers within a given weight range
- vi) Four Axle Trucks within given weight ranges
- vii) Five Axle Trucks within given weight ranges
- viii) Six Axle Trucks within given weight ranges

2.2 Accuracy

The AVC shall determine classes to an accuracy of at least 99%.

2.3 AVC Vehicle Separation Performance

The AVC system will differentiate between vehicles separated by a minimum of 1 meter at speeds of less than 60 kilometers per hour.

2.4 Interfaces

Sending vehicle's presence and class from the AVC to the host computer. Presence information can be used for vehicle separation.

3.0 SYSTEM DESIGN

The AVC system consists of the light curtain, Doppler radar and twin quartz sensors. This system is capable of providing the classification accuracy to meet the requirements defined in Section 3.

The block diagram of the AVC is shown in Figure 3.0-1 below :

Figure 3.0-1; AVC Block Diagram

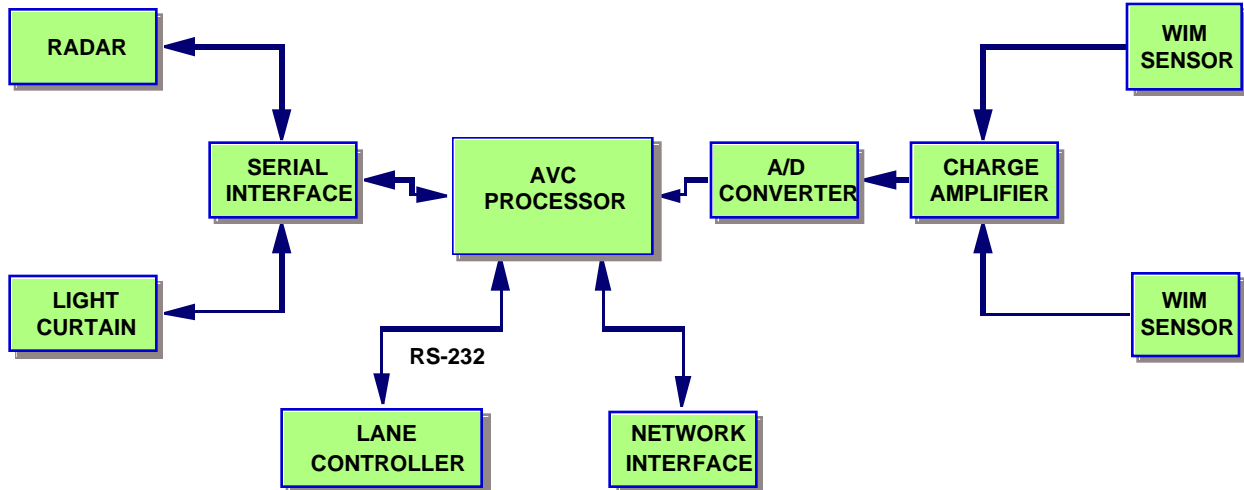

The lane layout for the AVC lane is shown in Figure 3.0-2 below :

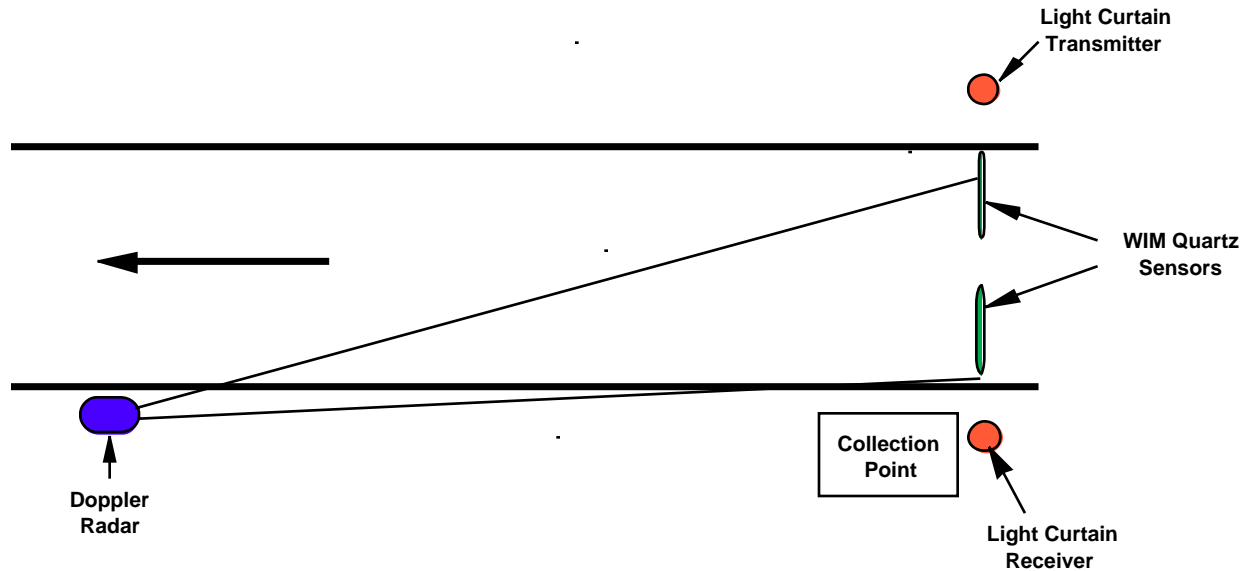

Figure 3.0-2; AVC Lane Sensor Layout

The vehicle class types will be detected according to a set of rules similar to those described below in Table 3.0-1.

Table 3.0-1 ; AVC Produced Classes - Sample

Vehicle Type	Toll Classification	Vehicle Characteristics
Motorbike	1	Length < 7 feet, Two or three axles (Sidecar)
Car	2	Length > 7 feet, < 20 feet Height < 6 feet Two axles Weight < 5000
2 Axle	3	Two axles, > 20ft w without a van/bus profile (height < 6 feet) Weight < 5000
2 Axle Truck	4	Two axles, > 20ft w without a van/bus profile (height > 6 feet) Weight > 5000
Van	5	Two Axles Height > 6 feet Length > 7 feet Flat Roof, Weight > 5000
3 Axle Truck – Empty	6	Axle count, Length, Axle Location, Height Profile. Rear Wheel Weight < 5,000
3 Axle Truck - Loaded	7	Axle count, Length, Axle Location, Height Profile. Rear Wheel Weight > 5,000
3 Axle Bus	8	Axle Count, Length, Axle Location
4 or More Axle Trucks	9	Axle count, Height Profile

The TDS AVC Automatic Vehicle Classifier:

- Meets all of the individual classification requirements Section 3.1 fare classes based on axles, vehicle weight and length and the vertical profile of the vehicle.
- Allows easy modification of classification categories to readily accommodate future rate structure changes or additional classes.
- Provides accurate vehicle velocity (max and/or average) – accuracy = 1% +/- 0.2 mph.
- Maintains the position of the vehicle at all times while in the collection zone. This includes stop and go operation as well as reverse motion.
- Transmits entry and exit information to the host processor. This information is used by the host processor to augment the lane logic.

- Is composed of off-the-shelf technology from major suppliers.
- Has a system MTBF in excess of 20,000 hours.

3.1 AVC Operational Philosophy

The automatic vehicle classification system described herein is a pattern recognition system that relies on special pattern recognition algorithms to categorize vehicles into a number of distinct types. It uses the length of the vehicle, the number, weight and spacing of axles, and a height matrix depiction of the vehicle to form a complex pattern. This pattern is then fed to discrimination software that correlates with one of a predetermined set of vehicle types. A picture of an actual profile of an automobile is shown in **Figure 3.1-1; Vehicle Profile**.

Figure 3.1-1; Vehicle Profile

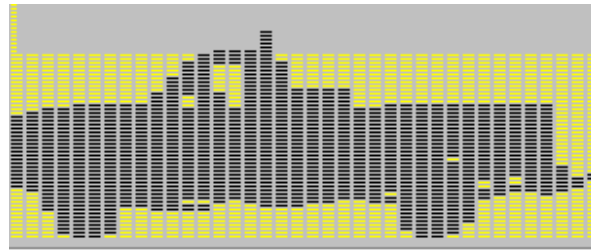

Vehicle detection and profiling are accomplished by processing the sensor data from the radar, light curtain, and weigh-in-motion sensors. The AVC processor receives frequent sensor messages from the radar and light curtain. Each radar message reports the distance and velocity of up to seven targets that the radar is currently sensing in its beam. Each light curtain message provides a report of the beam status of each of the 120 beams. The axle sensor inputs are sampled each time a light curtain message is received. The vehicle detection process begins when the light curtain reports sufficient penetration concurrent with a radar report of an object moving in the vicinity of the lane in the path of the light curtain beams. A filter is implemented to eliminate false classifications from being reported due to penetration of the light curtain by objects other than vehicles.

While the light curtain is sufficiently penetrated, the processor creates a profile of the vehicle using the Doppler radar velocity information to determine which position in the vehicle profile to store each light curtain and treadle sample. This process continues until the light curtain no longer detects a presence in the path of the light curtain beams. The vehicle profile is then sent to the correlation process where the classification will be determined.

The correlation process begins with the series of tests to determine the characteristics of the vehicle. These characteristics are the length of the primary vehicle, the presence/location of a hitch, the maximum height and height variance of the primary vehicle, the number of axles and their weights and locations, and certain other discrimination criteria. The test results are then correlated with a table of characteristic values that is configured for the user classification

schedule. This table of characteristics is stored in a configuration file that is separate from the AVC application software. This provides an easy method for updating the class schedule should the user require modifications. After the classification has been determined the classification message is transmitted to the lane controller application. The classification message includes the maximum velocity of the vehicle measured during the period that it was within the light curtain. The message also includes the vehicle height, weight and length as well as the total axle count.

After the vehicle has been classified the system continues to track the location of the vehicle in the lane.

A key element in this design is the use of the CW Doppler radar. When vehicles are traveling at higher speeds, the problem of resolving two vehicles in close proximity is particularly vexing. However one characteristic that these two vehicles have in common is that their velocities are obviously very nearly the same. Therefore the Doppler return from each of the vehicles is also nearly the same. The light curtain acts to provide excellent vehicle separation. The current design allows for separating two vehicles that are within 4 feet of each other at a velocity of 100 miles per hour. At more reasonable speeds (60 mph), the vehicles may be within two feet of each other and at manual lane speeds, the vehicles may be within 8 inches of each other. The processor uses the velocity provided by the Doppler radar to determine the positioning of the various samples in the vehicle profile. Since in this particular case the velocities of the two adjacent vehicles and the corresponding Doppler radar outputs are nearly identical, errors in the sampling distance that are due to returns from the adjacent vehicle are negligible.

The output from the Doppler radar provides an excellent measure of the vehicle velocity. This data is used to calculate the weight of each wheel set as the wheel crosses the quartz sensor. This data will be transmitted to the lane controller as part of the primary AVC message.

The AVC software can provide any/all of the following functions:

- Receipt of data from the radar
- Receipt of data from the light curtain
- Receipt of data from the axle detector
- Vehicle presence detection
- Vehicle position tracking through the collection zone
- Determination of the vehicle classification
- Vehicle speed
- Lane entry and exit messages
- Vehicle At ACM message for associating coins with a vehicle
- AVC system diagnostics (remote or local)
- Error reporting to the host processor

The processor will be able to handle all types of vehicle motion including negative speeds. It will identify back-outs and terminate the transaction.

4.0 DETAILED DESCRIPTION – EQUIPMENT

4.1 STI Light Curtain

The Light Curtain is a Model VS 6500 Vehicle Scanner manufactured by Scientific Technologies Inc. (STI). The Light Curtain consists of 120 vertically mounted, infrared beams housed in a rugged aluminum case.

The specifications for the scanner are as follows:

- 10 foot high consisting of 120 infra-red beams (80 beams at vertical spacing of 0.75 inches, 40 beams at vertical spacing of 1.5 inches).
- RS422 interface to AVC processor
- High degree of immunity to all kinds of ambient lighting
- Non-volatile RAM to store user's settings
- Special software ignores small objects such as snow flakes while still detecting narrow trailer hitches.
- 220/240 VAC (50 Hz) Power Supply.

The curtain functions solely as a sensor providing raw data to the AVC processor. The data supplied by the curtain supports the primary profiling function in addition to requirements for axle detection. The curtain will consist of a pair of primary stanchions containing respectively, the transmit and receive elements required for 120 beams. The curtain is supplied by Scientific Technology Incorporated (STI).

4.1.1. Curtain Array

The light curtain array will be ten feet in height and will contain 120 beams. The bottom five feet of the curtain will contain 80 beams at a beam spacing of 0.75 inch. The top five feet will contain 40 beams at a beam spacing of 1.5 inches. The lower segment of the curtain, with the tight beam spacing will readily detect a hitch with a vertical width of one inch.

4.1.2. Curtain Processor

A single curtain processor will be supplied which controls the polling of the curtain and the secondary elements. The processor scans the entire 120 elements in approximately 7 milliseconds. The data is transferred in a 15 byte message at 38.4 kilobits/second. The standard processor is mounted in a NEMA case. The unit will operate from 220 VAC input. The maximum input power requirement is 100 mA.

4.1.3. Stanchion Enclosures

Enclosures will be supplied to protect the transmit and receive structures from the environment. The enclosures will include environmental controls to adequately control the internal temperature and humidity of the enclosures. Each unit will have a front door, which will open to provide access to the actual equipment. Each door will contain a

	Model 310 AVC System	1261C Rosecrans Street San Diego, CA 92106 (619) 226-2534
--	----------------------	---

special window through which the beams are transmitted and received. Internal heating will ensure that condensation does not build up on the windows. Each housing will require 220 VAC @ 1.5A for the operation of the environmental control unit.

4.2 Eaton Vorad Doppler Radar

The Doppler Radar consists of the following components:

- Radar Antenna assembly
- Power Supply (220/240 VAC)
- Radar Mounting
- Power and communication cables
- RS422 interface to AVC Processor



The Doppler CW radar is a Ku band (24.725 Ghz) radar produced by Eaton Safety Systems. It is designed to provide coarse position and very accurate velocity data on moving vehicles. Coarse position is provided by a 50 kilohertz frequency shift keying applied to the transmitted signal. Velocity data is provided by the Doppler offset of the received signal. The received signal is mixed with a coherent transmitter signal to produce in-phase and quadrature Doppler signals, which are then sampled and fed to a digital signal processor, implemented as a Fast Fourier Transform (FFT). The outputs of the FFT are correlated with the coarse range data to provide data on up to seven separate targets.

The radar was originally designed to be part of a vehicle mounted collision avoidance system that is now being sold in production quantities by Eaton. The radar is a weatherproof unit, packaged to withstand extremes in temperature and humidity. As sold by Eaton, the unit is mounted above the front bumper on a vehicle and provides target information about vehicles directly ahead of the instrumented vehicle.

The radar is a very low power device (< 5 milliwatts CW). It has complete FCC approval (FCC ID 13L3JC) for operation on the open road and is not an RF hazard to humans under any conditions.

The antenna unit is a planar array. The horizontal beam width is 12 degrees and the vertical beam width is 4 degrees.

The radar processor provides a variable length message containing range and range rate on up to seven targets to the processor. This message is transmitted to the processor every 65 milliseconds. The interface is a 19200 bps RS-422 interface. The resolution of the range is 1 foot and of the range rate is 0.1 foot per second. The accuracy of the range reading has limited value as the phase center tends to move about the vehicle as it passes through the radar beam. On the other hand the accuracy of the range rate is 1% +/- 0.2 miles per hour. The unit will handle velocities up to a maximum of 120 miles per hour and ranges up to 350 feet.

The unit is capable of operating in a temperature range of - 40 degrees to + 85 degrees Centigrade.

The radar requires a maximum of 10 watts of power from a regulated 7.5 VDC source. As shown below, the Doppler Radar is mounted approximately 35-40 feet “downstream” of the Light Curtain, with the top of the antenna positioned 2-3 feet above the road surface. The unit should be located a maximum of 2 feet from the edge of the lane. The radar antenna should have an unobstructed view of the lane to the light curtain. The power supply must be located within 6 feet of the radar unit.

4.3 Axle Detector

The axle detector will consist of two 1 meter quartz sensors connected to a charge amplifier.

4.3.1. Quartz Sensor

Kistler's LINEAS WIM Type 9195C is a force sensor with quartz elements. The sensor is a modular element that is installed into a slot that is saw-cut across an asphalt or concrete road. When a force is applied to the sensor surface, the quartz disks yield an electric charge proportional to the applied force through the piezoelectric effect. The electric charge is converted by a charge amplifier into a proportional voltage which can then be processed as required. Key characteristics include:

- Excellent long term stability.
- Measures very accurately at both walking and freeway speeds.
- Insensitive to temperature changes.
- Frost-resistant and protective against ingress of water.
- Quasistatic and dynamic calibration is possible.
- Wide measuring range.

The sensor is not dislodged from the road and can be reground by up to 10 mm in the event of road deformations.

The sensors are available in 0.75 and 1.0 meter lengths. Two or more sensors can be connected together to make a longer single sensor strip. Several sensors that are installed adjacent to one another can be connected electrically in parallel and operated with a single charge amplifier. The output signal then corresponds to the sum of the forces acting simultaneously on all sensors connected.

4.3.2. Charge Amplifier

The industrial charge amplifier (Type 5038A2Y43) is a 2 channel amplifier. Each channel converts the charge output of the Lineas sensor to a proportional voltage. The adjusting potentiometers are designed as plug in units to avoid the need for recalibration when an amplifier is replaced. The unit requires an unregulated 15 to 20 volt DC supply. Its key features include:

- Robust aluminum diecast housing
- Vibration proof
- No adjustments required

4.3.3. Lane Controller Interface

The outputs of the sensor amplifier are brought to the lane controller over special cables capable of extending the distance from the sensor amplifier to over 80 feet. The signals are fed into a digital processing card that contains a 12 bit analog to digital converter.

4.4 AVC Processor

The AVC software module will be installed on an AVC Processor. TDS offers a choice of two different AVC processors. One is for installation inside a controlled environment like the plaza and the other is for external installations.



For the inside installation, the processor is a Dell Series 600 server or equivalent. It uses a Celeron processor. It includes 128 megabytes of RAM and a 20 Gb hard drive. It will contain an Ethernet port for LAN connection. The unit will run the Linux operating system.

For an external installation, the processor is a hardened PC designed to be installed in tunnels and open air booths. It uses a Celeron processor. It includes 128 megabytes of RAM and a 20 Gb hard drive. It will contain an Ethernet port for LAN connection. The unit will run the Linux operating system. The unit is equipped with a heat exchanger to allow for completely sealed operation.



The AVC unit will be equipped with a two channel RS-422 serial channel board and an analog to digital converter board for interfacing to the sensors. The AVC unit will include an RS-232 port for interfacing with the host computer. One processor is required for each lane.

In the event the user system design incorporates a lane controller running Linux or Windows XP/2000, the AVC software can be integrated into the lane controller. This does require a development effort by the system integrator.

5.0 INSTALLATION

5.1 Curtain Installation

The curtain consists of the transmit and receive elements with their enclosures and the processor unit. An STI supplied cable connects each of the two external elements with the processor unit.

5.1.1. Transmit/Receive Tower Installations

A pair of enclosures must be installed along the edge of the lane. The enclosure plate should be installed at a consistent distance above the roadway. Typically this should be approximately 6 to 8 inches above the level of the pavement. AC power must be brought to the enclosures in order to power the completely self-contained environmental control units.

Once the enclosures have been installed, the curtain transmit and receive elements are bolted into the enclosures and aligned. The curtain transmit and receive elements can be moved in both horizontal angle (azimuth) and vertical height to allow for alignment of the curtain. A separate gain control in the curtain processor is then adjusted to maximize the sensitivity of the light curtain thereby optimizing its ability to see small hitches.



5.1.2. Curtain Processor Installation

The curtain processor consists of an industrial case containing a power supply and a processor board. The power supply provides power to the processor board. The unit should be installed in the booth. The power supply will require 220 VAC power.

5.1.3. Curtain Cabling Installation

A single RS-422 cable will connect the curtain processor to the lane controller in the plaza. TDS assumes that the customer will provide the cable for this installation. Two STI supplied cables connect the curtain processor with the external transmit and receive elements. These cables are provided by TDS as part of the light curtain.

5.2 Radar Installation

The radar installation consists of:

- Mounting the radar mount on the island.
- Mounting the radar power supply near the radar antenna. The radar power supply will need to be put into an enclosure for external mounting.
- Installing a single cable between the power supply and the antenna.
- Installing a single cable between the radar and the AVC processor in the plaza.



5.2.1. Radar Antenna Installation

TDS has designed and built a small pedestal mount for the Doppler radar. The mount is adjustable in both azimuth and elevation. The mount is attached to the island with four bolts. The mount is adjustable in both azimuth and elevation to allow for beam alignment of the radar.

5.2.2. Radar Power Supply Installation

The radar requires a special 7.5 volt DC power supply. TDS will supply this power supply in a separate rugged container for installation near the radar installation. This unit must be installed within 3 meters of the radar.

5.2.3. Radar Cabling Installation

A single cable connects the radar antenna/processor to the AVC processor and the radar power supply. The cable will be supplied with the radar connector installed and the power supply/AVC processor connections left un-terminated.

5.3 Quartz Sensor Installation

Special sand/epoxy grout secures the sensor strips into the pavement slots. After curing, the hardened grout and the exposed top surfaces of the sensor modules are ground flush with the surrounding pavement using a belt sander. After grinding, the sensors may be immediately exposed to traffic. An overnight post cure is recommended before calibration and acceptance tests are performed.

Installation instructions for the installation of the sensors will be provided by TDS. The potting compound used to install the sensors will be supplied by TDS.

	Model 310 AVC System	1261C Rosecrans Street San Diego, CA 92106 (619) 226-2534
--	----------------------	---



5.4 AVC Processor Installation

The AVC processor can be located anywhere within 500 feet of the lane.